



2017 Ford F250/F350 6-3/4 Ft Bed
Bracket Kit
IN 630

Product No.
74005 75005
84005 31006

Hardware included shown on right.

No Drilling into Vehicle is Required

Tools required:

- 1/2" wrench
- Ratchet
- 1/2" Socket
- 3/4" Socket
- 21mm Deep Socket / 13/16"
- Tape measure
- 1/8" Allen Wrench
- Vice Grip Pliers

Torque Specification:

- M14 Nut - 68 Ft Lbs.
- 1/2" Nut - 48 Ft Lbs.
- 5/16" Bolt - 19 Ft Lbs.
- 1/4" Set Screw - 10 Ft Lbs.

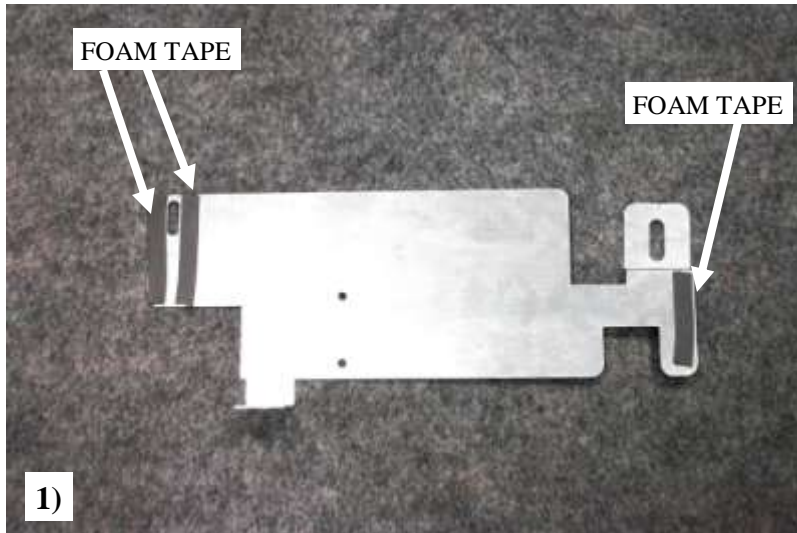
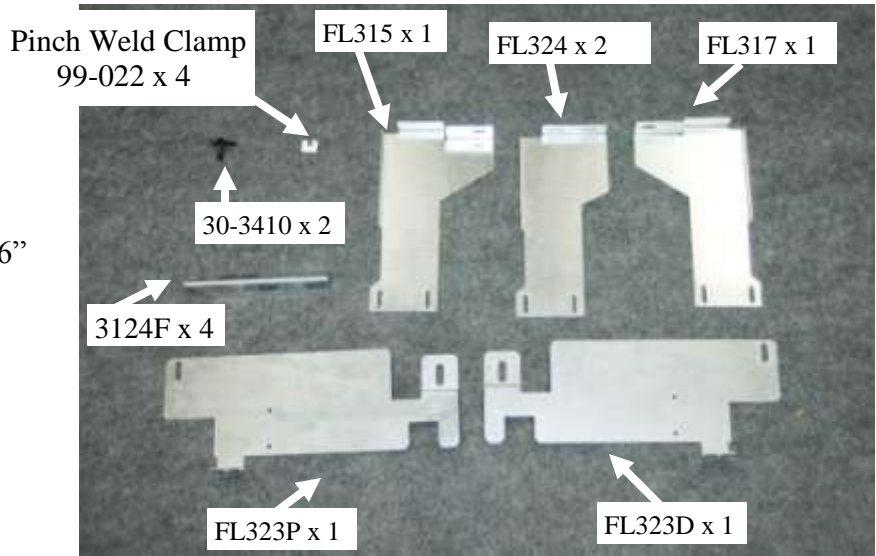

Place a strips of foam tape on the top of the both the FL323D and FL323P bracket as shown in photo, this will insulate the steel bracket from the aluminum body to avoid corrosion.

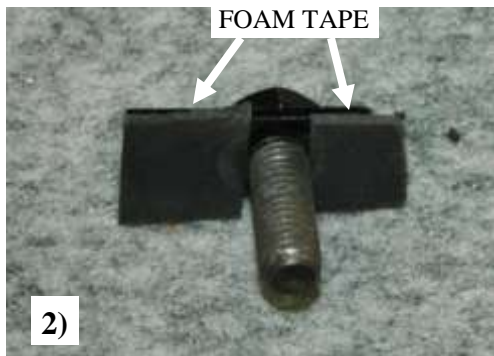

Place a strips of foam tape on both sides of the threads of the 30-3410 stud plates as shown in photo above, this will insulate the steel bracket from the aluminum body to avoid corrosion.

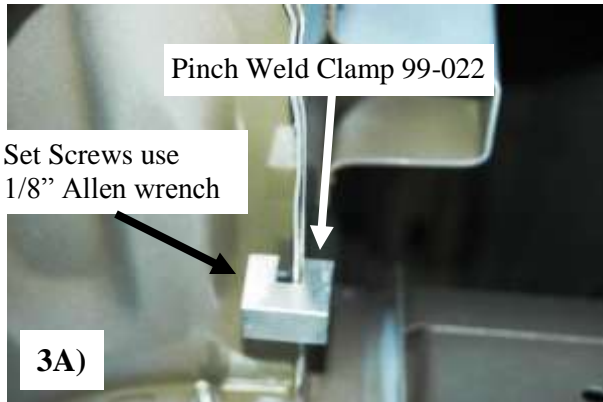

Driver Side

Place a 99-022 pinch weld clamp up onto the pinch weld as shown in photo **3A**, this will be at 4 1/8" from the front of where the pinch weld starts to the center of the 99-022. photo **3B** Tighten the set screws as tight as possible by hand to secure clamp onto the pinch weld. Make sure the set screws are located on the inside of the vehicle tightening outward as shown in photo **3A**

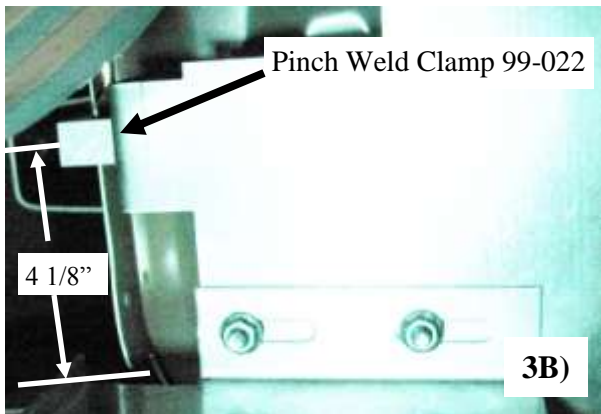

Use pair of vice grip pliers to hold the 99-022 when tightening the set screws, this will give better leverage.

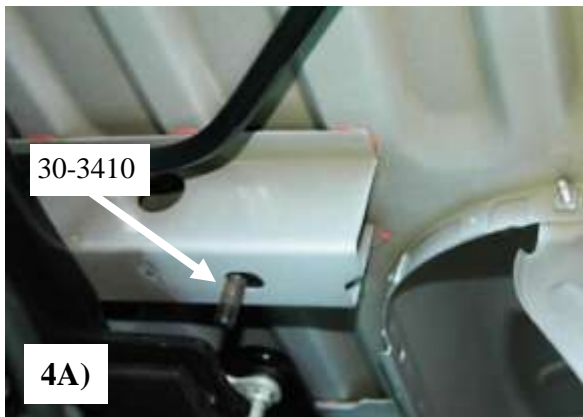

Slide the 30-3410 stud plate into the second bed cross brace so that the threads drop down through the slot in the cross brace as shown in photo **4A**

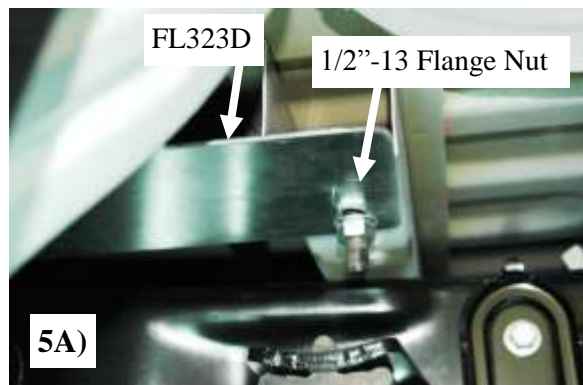

Slide the FL323D up over the threads of the 30-3410 stud plate and place a 1/2-13 flange nut onto the threads to secure. Photo **5A**

The other end of the FL323D slot will need to slide over the M14 threads located on the front bed cross brace. The flange that is bent upward with the slot should line up with the threaded hole in the 99-022 pinch weld clamp. Thread a 5/16" x 3/4" flange bolt through the slot in FL323D and thread into the 99-022 pinch weld clamp to hold FL323D in place.

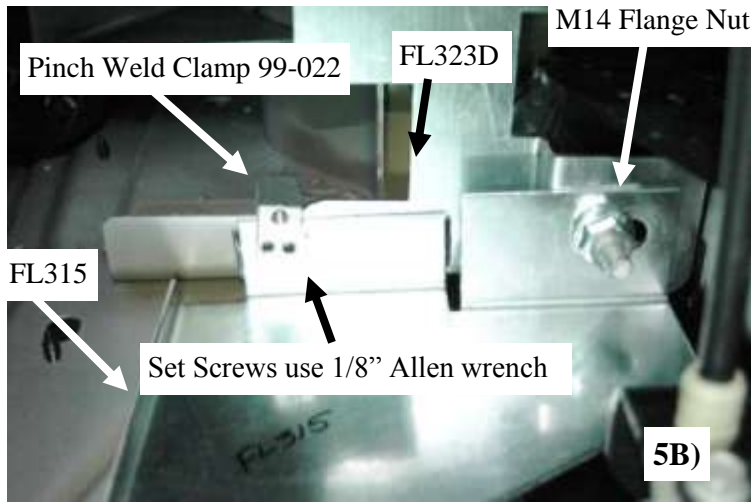

Slide the FL315 bracket up onto the M14 threads on the front bed cross brace. Thread the M14 flange nut onto the threads tighten completely, making sure the FL315 is slid all the way back in top slot use 21mm deep socket or 13/16" if a metric socket is not available.

Once the nut is tight, place a 99-022 pinch weld clamp with the set screws installed with 1/8" Allen wrench over the flange of the front bed cross brace and the FL315 and tighten approximately 1/2" from the edge of the FL315 bracket as shown in photo 5B

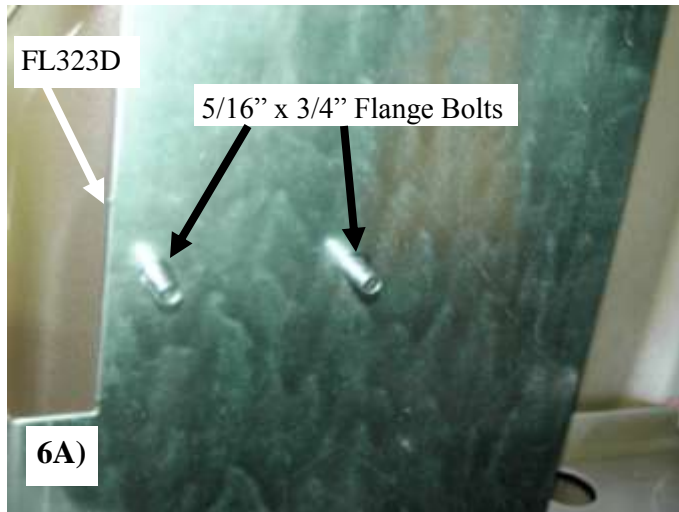

Place two 5/16" x 3/4" flange bolts down through the holes in the FL323D from the top, so the threads point downward shown in photo 6A

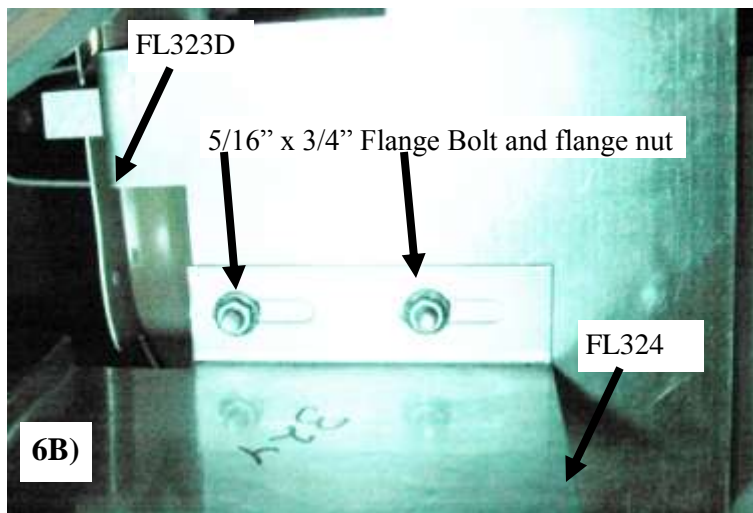

Put the FL324 bracket top slots over the two bolts coming down out of the FL323D, and secure with two 5/16" flange nuts shown in photo 6B, Hand tighten for adjustment when boards are mounted.

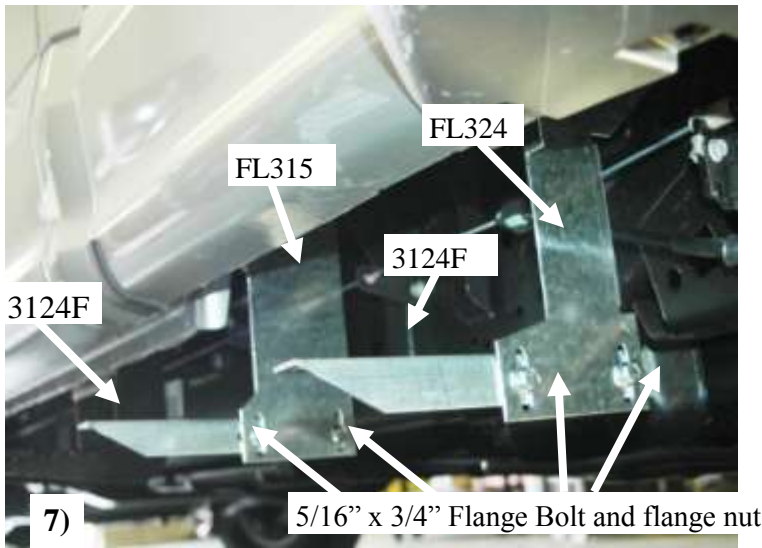

Mount the 3124F angles to the FL315 and to the FL324 lower slots with 5/16" x 3/4" flange bolts and flange nuts through each slot as shown in photo 7

Leave loose for adjustment once board is mounted onto vehicle.

Passenger Side

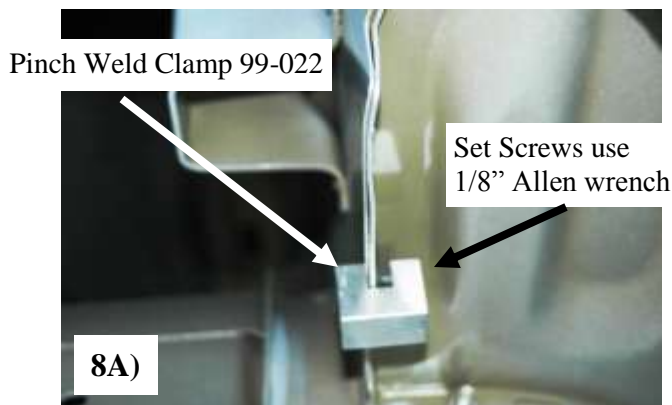

Place a 99-022 pinch weld clamp up onto the pinch weld as shown in photo 8A, this will be at 4 1/8" from the front of where the pinch weld starts to the center of the 99-022. photo 8B Tighten the set screws as tight as possible by hand to secure clamp onto the pinch weld. Make sure the set screws are located on the inside of the vehicle tightening outward as shown in photo 8A



Use pair of vice grip pliers to hold the 99-022 when tightening the set screws, this will give better leverage.

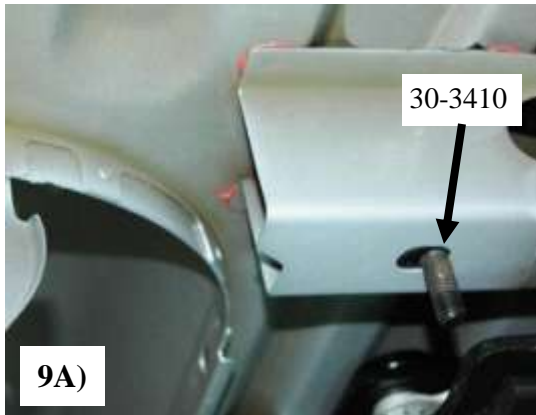

Slide the 30-3410 stud plate into the second bed cross brace so that the threads drop down through the slot in the cross brace as shown in photo **9A**

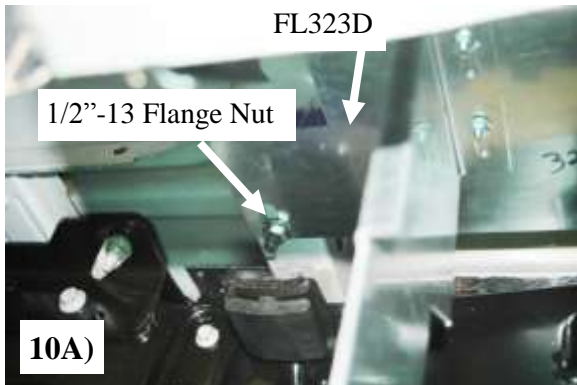

Slide the FL323P up over the threads of the 30-3410 stud plate and place a 1/2-13 flange nut onto the threads to secure. Photo **10A**
 The other end of the FL323P slot will need to slide over the M14 threads located on the front bed cross brace. The flange that is bent upward with the slot should line up with the threaded hole in the 99-022 pinch weld clamp. Thread a 5/16" x 3/4" flange bolt through the slot in FL323P and thread into the 99-022 pinch weld clamp to hold FL323P in place.

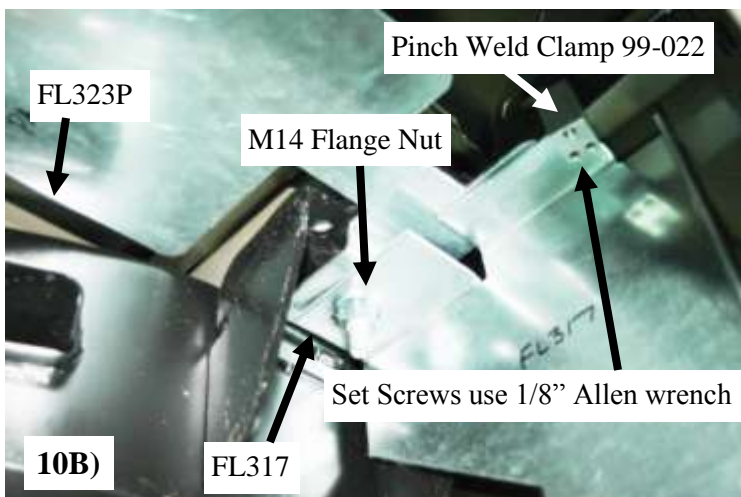

Slide the FL317 bracket up onto the M14 threads on the front bed cross brace. Thread the M14 flange nut onto the threads tighten completely, making sure the FL317 is slid all the way back in top slot use 21mm deep socket or 13/16" if a metric socket is not available.
 Once the nut is tight, place a 99-022 pinch weld clamp with the set screws installed with 1/8" Allen wrench over the flange of the front bed cross brace and the FL317 and tighten approximately 1/2" from the edge of the FL317 bracket as shown in photo **10B**

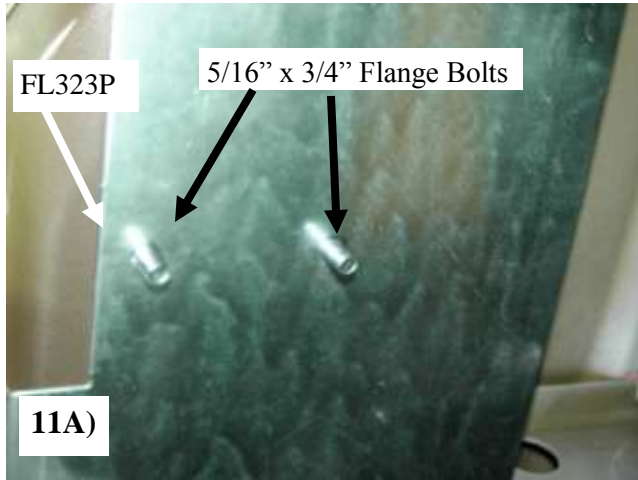

Place two 5/16" x 3/4" flange bolts down through the holes in the FL323P from the top, so the threads point downward shown in photo **11A**

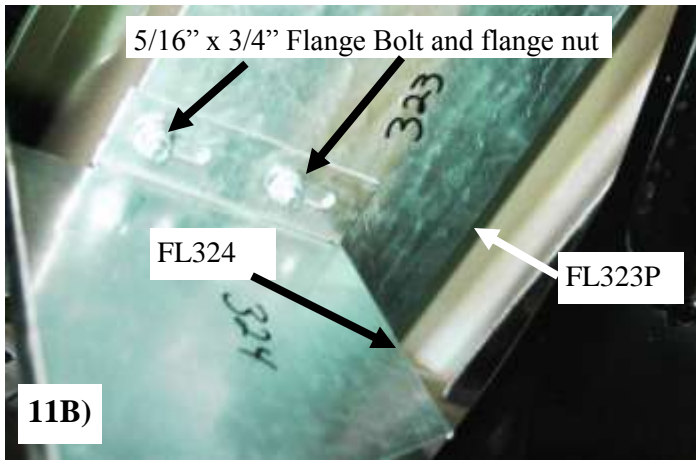

Put the FL324 bracket top slots over the two bolts coming down out of the FL323P, and secure with two 5/16" flange nuts shown in photo **11B**, Hand tighten for adjustment when boards are mounted.

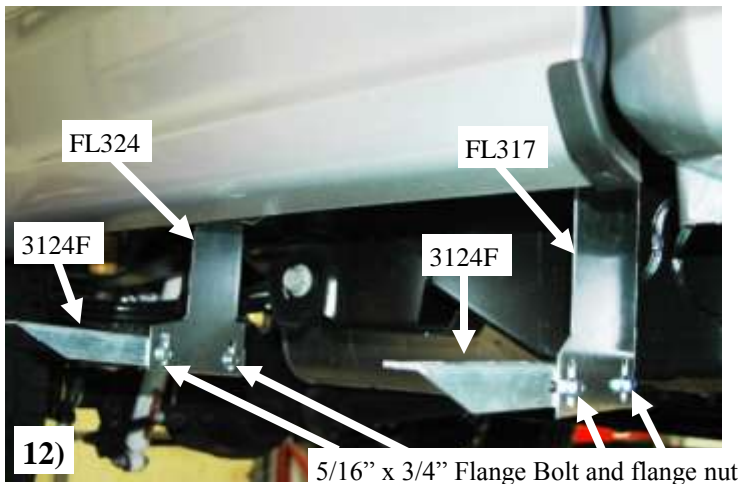

Mount the 3124F angles to the FL317 and to the FL324 lower slots with 5/16" x 3/4" Flange bolts and flange nuts through each slot as shown in photo **12**

Leave loose for adjustment once board is mounted onto vehicle.

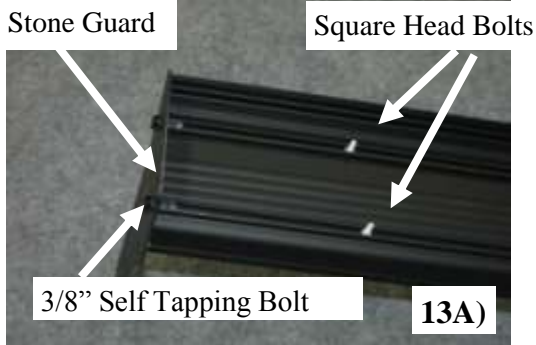

For Aluminum Boards

Slide square head bolt into both the front track and rear track for each bracket location. After sliding all bolts into track mount the front stone guard onto board using two 3/8" self tapping bolts into tracks that the square head bolts were inserted into. Make sure the tread tape is facing inward to match on board.



Mount the end cap onto board using two 3/8" self tapping bolts into tracks that the square head bolts were inserted into. Make sure the tread tape is facing inward to match on board.

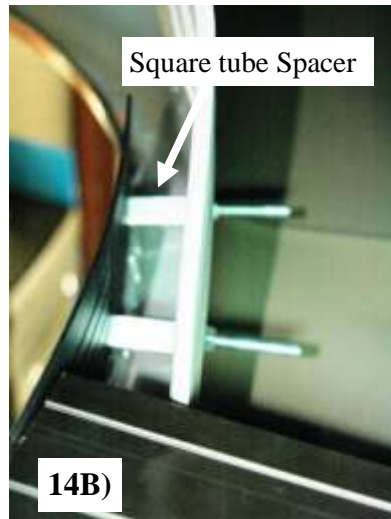
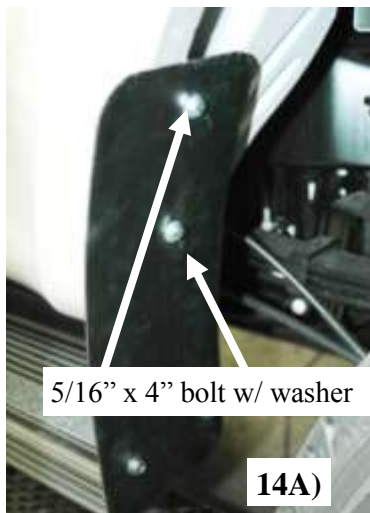

Once the board is tight and all bolts on bracket are tight. Reach in on inside of truck wheel well in photo 14C and mark through the two lower slots onto the aluminum stone guard. Remove the stone guard from board and drill 5/16" hole stone guard for the 5/16" x 4" bolts to fit through. Reinstall stone guard to board. Place 5/16" x 4" bolt through a flat washer, 14A and as inserting bolt place the square tube in position so threads go through the center of tube and through the truck slot see photo 14B Install a plastic washer on to threads then secure with 5/16" flange nut in both locations shown in photo 14C



2017 Ford F250/F350 6-3/4 Ft Bed
Bracket Kit
IN 630

Product No.
74005 75005
84005 31006

For Fiberglass Boards



Using self drilling screws attach the board to the angle brackets making sure you are drilling into steel mounting pads. Level board and tighten any remaining loose bolts at this time.

Once the cab boards are mounted onto vehicle adjust the 3124F angle bracket so that the boards on the bed are level with the cab boards and tighten all bolts completely.

